

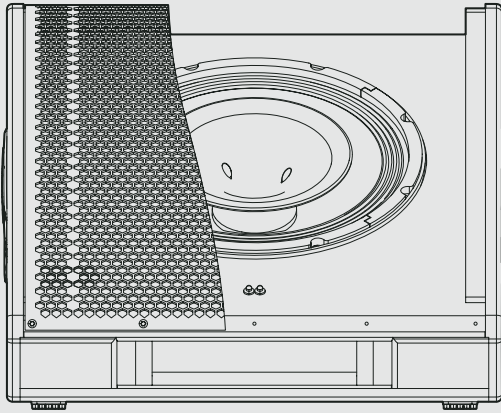

AUDIOTECHNIK

# SMX 12A

SELF POWERED 12" COAXIAL MONITOR



## MANUAL

## THANK YOU FOR CHOOSING S)))e AUDIOTECHNIK®.

We are happy to be the solution for your sound reinforcement and professional sound needs. The system you purchased is the sum of 20 years of experience as a loudspeaker manufacturer, and more than 40 years as a speaker designer. It is the sum of German precision and Chinese efficiency, which ensures a high-quality product that will last you for the long-term.

Please, take the time to carefully read this manual and follow its instructions. It will allow you to get the most out of your product under safe operating conditions and suggest some care instructions leading to long-term endurance. Keep this manual in a safe place for further reference!

If you find any mistakes or have further questions or suggestions, please contact us at **info@se-audiotechnik.de**.

For more information about **SE AUDIOTECHNIK®** products, visit our website **www.se-audiotechnik.de**. There you will also find the latest updates to manuals, firmware and technical documents for additional support.

© Copyright by **SE AUDIOTECHNIK®** 2021. All rights reserved.

The content of this document is subject to change without prior notice to improve reliability, function, design or otherwise.

# LIST OF CONTENTS

<b>IMPORTANT SAFETY INSTRUCTIONS</b>	<b>6</b>
<b>PACKAGE CONTENTS</b>	<b>9</b>
<b>INTRODUCTION</b>	<b>10</b>
Features	10
Amplifier panel	11
Input panel	12
LED indicators	13
<b>WIRING AND INSTALLATION</b>	<b>14</b>
U-bracket mounting	15
Wall mounting	18
<b>APPLICATIONS</b>	<b>19</b>
Monitor	19
PA system with subwoofer	19
<b>SPECIFICATIONS</b>	<b>20</b>
Technical Specifications	20
Mechanical Drawings	21
<b>MANUFACTURER'S DECLARATIONS</b>	<b>22</b>
<b>ANNEX A – PRESETS PROFILE CURVES</b>	<b>23</b>

# IMPORTANT SAFETY INSTRUCTIONS

## GRAPHICAL SYMBOLS IN THE PRODUCT



The lightning bolt triangle is used to alert the user to the risk of electric shock.



Symbol indicating that the equipment is for indoor use only.



The exclamation point triangle is used to alert the user to important operating or maintenance procedures and instructions.



Symbol for conformity with Directive 2002/96/EC and Directive 2003/108/EC of the European Parliament, on waste electrical and electronic equipment (WEEE).



The CE mark indicates the conformity with the relevant EU directives for safety, health and environmental protection. See the Manufacturer's Declaration section.



Symbol for ground connection.

## GRAPHICAL SYMBOLS IN THIS MANUAL



Symbol for important safety information related with the risk of electric shock.



Symbol for important concepts and information for a better understanding of the functioning of the product.



Symbol to alert the user about important operating or maintenance instructions.



Symbol for practical tips and ideas useful to ensure the correct use of the product and improve its operation.

This unit has been engineered and manufactured to ensure your personal safety. However, **IMPROPER USE CAN RESULT IN POTENTIAL ELECTRICAL SHOCK, FIRE HAZARD AND OTHER HEALTH RISKS.** Always follow the basic precautions listed here to avoid the possibility of serious injury or even death from electrical shock, short-circuiting, damages, fire or other hazards. These precautions include, but are not limited to, the following items in this chapter.



## ELECTRICAL SAFETY PRECAUTIONS



DO NOT EXPOSE THIS EQUIPMENT TO RAIN OR MOISTURE, DRIPPING OR SPLASHING LIQUIDS. OBJECTS FILLED WITH LIQUIDS, SUCH AS VASES, SHOULD NOT BE PLACED ON THIS APPARATUS.



TO REDUCE THE RISK OF ELECTRIC SHOCK, DO NOT ATTEMPT TO OPEN ANY PART OF THE UNIT. NO USER-SERVICEABLE PARTS INSIDE. REFER SERVICING TO QUALIFIED SERVICE PERSONNEL.



TO COMPLETELY DISCONNECT THIS EQUIPMENT FROM THE AC MAINS, DISCONNECT THE POWER SUPPLY CORD PLUG FROM THE AC RECEPTACLE. THE MAINS PLUG OF THE POWER SUPPLY CORD SHALL REMAIN READILY OPERABLE.

## NOISE EXPOSURE PRECAUTIONS



THIS PRODUCT CAN RADIATE HIGH SOUND PRESSURE LEVELS (SPL), THAT CAN LEAD TO IRREVERSIBLE HEARING DAMAGE. SE AUDIOTECHNIK® RECOMMENDS TO RESPECT THE TIMES OF EXPOSURE TO HIGH SPL.

Noise level (dBA)	85	94	97	112	127
Max. recommended exposure time per 24 hours	8 hrs.	1 hr.	30 min.	56 sec.	1 sec.

Noise exposure recommendations according to US National Institute for Occupational Safety and Health (NIOSH).

## IMPORTANT SAFETY INSTRUCTIONS

1. Keep these instructions.
2. Read these instructions.
3. Follow thoroughly all instructions.
4. Heed all warnings.
5. Do not use this apparatus near water.
6. Clean only with a dry cloth. Disconnect the device from the AC outlet before cleaning. Do not use paint thinners, solvents, cleaning fluids, or chemical-impregnated wiping cloths.
7. Do not block any ventilation openings. Install in accordance with the manufacturer's instructions.
8. Do not install near any heat sources such as radiators, heat registers, stoves, or other apparatus (including amplifiers) that produce heat.
9. Do not defeat the safety purpose of the grounding-type plug. A grounding-type plug has two blades and a third grounding prong. The third prong is provided for your safety. If the provided plug does not fit into your outlet, consult an electrician for replacement of the obsolete outlet.
10. Protect the power cord from being walked on or pinched particularly at plugs, convenience receptacles, and the point where they exit from the apparatus.
11. Unplug this apparatus during lightning storms or when unused for long periods of time.
12. Use the mains plug to disconnect the apparatus from the mains.
13. Keep away from objects which may be impaired by an external magnetic field. To avoid the damage of equipment such as computers, video monitors and magnetic data carriers, they should be located at least 1 meter away.
14. Only use safety pins, attachments, accessories and adapters specified and/or provided by the manufacturer.
15. Refer all servicing to qualified service personnel. This is required when the product has been damaged in any way, such as power-supply cord or plug is damaged, liquid has been spilled or objects have fallen into the apparatus, the apparatus has been exposed to rain or moisture, does not operate normally, or has been dropped.
16. Do not insert your fingers, hands or any other foreign objects into any gaps or openings of the device.
17. When this product reaches its end of life, take it to a collection point designated by local authorities. The separate collection and recycling of your product at the time of disposal will help conserve natural resources and ensure that it is recycled in a manner that protects human health and environment.

## PACKAGE CONTENTS

The packaging of the SMX 12A includes:

- 1 SMX 12A monitor
- 1 AC power cord with powerCON® connector
- 1 SMX 12A user manual
- 1 QC PASS card
- 1 Warranty card

Please inspect your product packaging before unboxing it. If it has been damaged during shipping, unbox the product and check for any visual damage before using it. Notify the shipping company immediately and contact your SE AUDIOTECHNIK® dealer or support center for help and assistance.

Finally, save the shipping carton as evidence for the possible claim, which can be requested only by you. We also recommend you to keep all the packing materials and contents for any further transportation.

## INTRODUCTION

The active SMX 12A is a compact, extremely versatile 2-way coaxial monitor in bass reflex design. Thanks to the built-in 12" LF with powerful 3" voice coil and a 1" HF with a 1.7" voice coil, the SMX 12A monitor is powerful and assertive in any mix and feature a harmonious, neutral sound character. This allows any musician to hear themselves better and bring out every nuance of their performance. The clearly audible signal in the 60° x 60° coverage angle is easy on any singer's voice - the more precise they hear themselves, the less effort is required for their performance. At the same time, the SMX 12 monitor remains uncomplicated and feedback-proof.

The SMX 12A boasts a 2-channel Class-D amplifier with a total power of 484 W (LF: 416 W @ 6.5 Ω, HF: 68 W @ 14 Ω) on board. So there is no need for an external device – the internal amp is optimally matched to the speakers and brings eight DSP presets to make the set-up as short and simple as possible.

SMX 12A monitors can also be used in combination with subwoofers such as the S 15 PRO for small to medium-sized events, or for fixed installations. The recessed I/O panel ensures a neat and tidy appearance on stage or in any other application. Equipped with M10 fly points and accessories like the SMX 12 UB U-bracket, SMX 12A can be utilized for applications where the speaker needs to be mounted to a wall, ceiling, truss or speaker stand. The optional padded cover SMX 12TC protects the monitor during transport and storage.



Figure 1. SMX 12A.

## FEATURES

- 12" high efficiency woofer
- 1.75" compression driver coaxially mounted
- Concentric waveguide
- 35° angled front
- Class-D amplification with DSP
- Gain and Preset selector, 8 factory settings
- Recessed I/O panel: no connectors, knobs or switches are visible to public
- 2 x M10 fly points
- 3 x handles for easy handling in all situations
- Octopus rubber feet for excellent grip
- Rugged front grill with fabric backing
- Polyurea coating

## AMPLIFIER PANEL

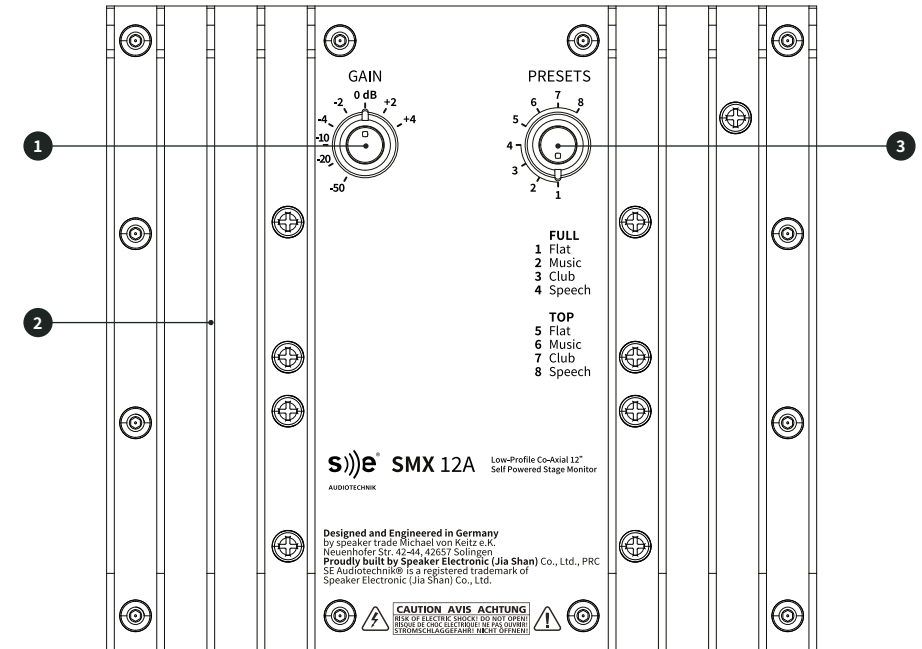



Figure 2. SMX 12A amplifier panel.

- 1 Gain.** Input signal level adjustment in eight discrete steps: -50, -20, -10, -4, -2, 0, +2 and +4. The nominal input sensitivity is +4 dBu, set with the knob on the 0 dB position.
  -  The standard Gain control position should be 0 dB, where the amplifier gain is set to the maximum, even if no signal is present. However, this may not be needed in many applications, especially when a professional mixer with high output capability is being used.
- 2 Amplifier heatsink.**
- 3 Presets.** Eight presets with different characteristics allow for setting the trend in sound that adapts best to your needs, while reducing the need of equalisation. The presets are separated into two groups:
  - **FULL:** presets 1 to 4, with extended response in the low frequencies to use the SMX 12A as a full-range box.
  - **TOP:** presets 5 to 8, with a high-pass filter at 120 Hz to run the SMX 12A with additional subwoofer for the lowest frequencies.

The profile of these presets can be found in Annex A - Preset Profile Curves.

## INPUT PANEL

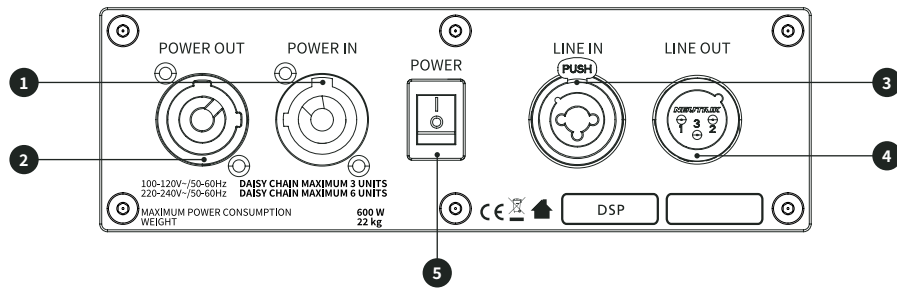

Figure 3. SMX 12A input panel.

- 1 **Power In.** PowerCON® type-A mains power socket. An appropriate power cable is included in the package. The SMX 12A is built for two operating voltage ranges: 100-120 and 200-240 VAC.
- 2 **Power Out.** PowerCON® type-B mains power output to link power between several units.
  - ⚠ The recommended maximum quantity of units to be connected in series is 3 for 100-120 VAC mains, and 6 units for 200-240 VAC. This is calculated for a standard 16 A mains supply.
- 3 **Line In.** Balanced line-level input with female Neutrik® XLR-3 connector to connect input signal. The input accepts levels up to +20 dBu.
  - 🔧 For an optimal signal-to-noise ratio, it is recommended to input signals with a level of at least 0 dBu. It is possible to chain up to 10 SMX 12A signal inputs. A built-in output buffer amplifier prevents any load problem for the signal source, like a mixer.
- 4 **Line Out.** Balanced and buffered line-level output with male Neutrik® XLR-3 connector. It shall be used to link other SMX 12A speakers or other components of the system like subwoofers.
- 5 **Power.** Switch to turn the unit on and off.

🔧 To avoid clicks and pops, turn on SMX 12A last and turn it off first before other connected devices. After turning the unit off, wait for more than five seconds before turning it on again. The internal voltage needs 5 seconds to drop completely, otherwise the power supply will not start up.

## LED INDICATORS

The intended use and application of SMX 12A makes it preferable, not to have any blinking, disturbing lights. Hence we refrained from adding signal or limit indicators.

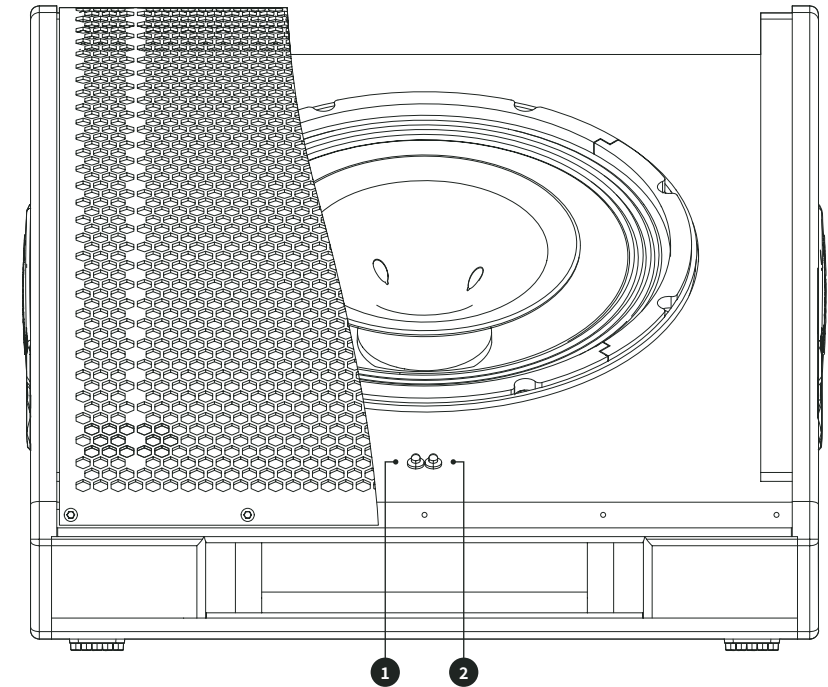

Figure 4. SMX 12A LED panel.

- 1 **Protect.** Lights red if the amplifier or SMPS has short-circuited or overheated and the amplifier output is muted automatically. In that case, turn off the mains switch and wait for the unit to cool down. Upon reaching normal operating conditions, turn on the mains switch and the device reverts to normal operating mode. If it does not, SMPS or Amplifier is damaged by other reason than overheating or short circuit.
- 2 **Power.** Lights green once the system is properly connected to the mains power and switched on.

## WIRING AND INSTALLATION

SMX 12A monitors use PowerCON® connectors for the mains power input and link. Figure 5 shows how to plug-in and connect these wires.

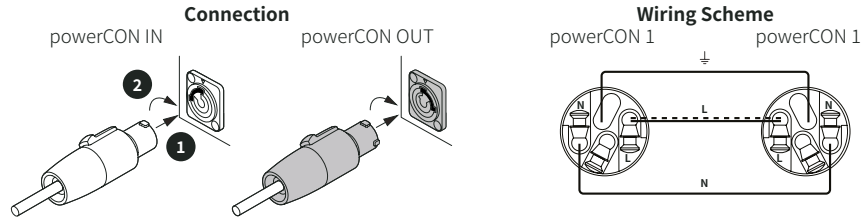

Figure 5. PowerCON® plug-in and link cable connection.

It is recommended to use cables with at least 18 AWG conductor size. For long cable lengths, the maximum conductor size is 14 AWG. Those wires must be assembled by a qualified technician.

For the audio signals, input and link are done through XLR-3 connectors. They follow the next plug-in and configuration scheme:

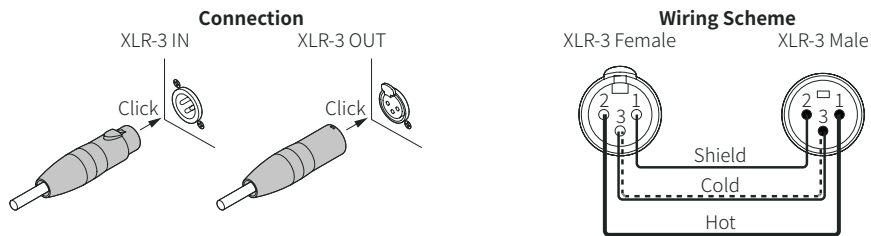

Figure 6. XLR-3 plug-in and link cable connection.

Using the U-bracket **SMX 12UB** and the **PS35** adapter, the SMX 12A can be mounted on a 35 mm standard speaker stand or mounted on a subwoofer with M20 thread, by using our **SPS20** pole bar. SMX 12A can also be used for permanent installation.

Depending on room dimensions, acoustics, positioning of SMX 12A and signal character, choose freely one of the presets which matches best your desired sound performance: if you use the SMX 12A as full-range box, choose one of the **FULL** settings. If you deploy additional subwoofers, use one of the **TOP** settings.

## U-BRACKET MOUNTING

The **SMX 12UB** U-bracket accessory contains:

- 1x **SMX 12UB** U-bracket
- 2x M10 handle screws
- 2x Steel washers
- 2x Silicone washers

As shown in figure 7, this accessory offers great installation versatility thanks to its three mounting positions:

- Position **A**: for ceiling and truss installation.
- Position **B**: to use with **SPS20** pole bar. See also figure 10.
- Position **C**: for a closer wall mounting.

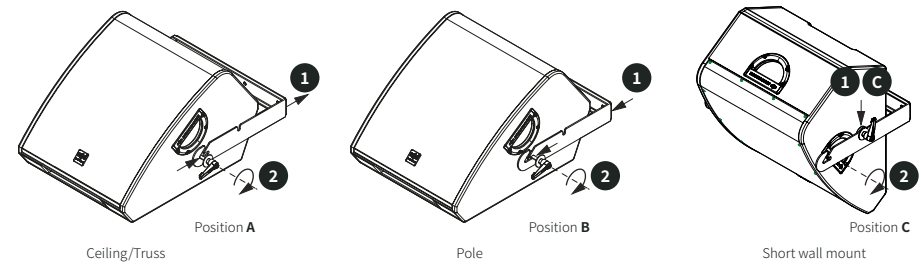
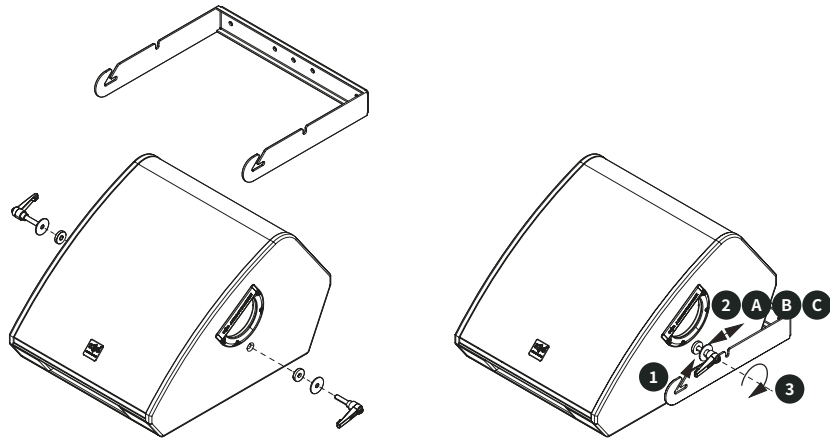

Figure 7. Different positioning options offered by the **SMX 12UB** U-bracket.

To attach the **SMX 12UB** U-bracket to the SMX 12A:

1. Unscrew the black countersink screws from M10 fly points on the left and right side of SMX 12A.
2. Onto the thread of each M10 handle screw, put first a steel washer and then, a silicone washer.
3. Fix the handle screws into the fly points. Turn 3 or 4 times to keep them in place.
4. Push the silicone washer close to the cabinet's side panel, and the metal washer close to the handle screw, so the U-bracket arm can easily get between both washers.
5. Place the U-bracket over the left and right handle screws. Make sure the U-bracket arms have the silicone washer at the side of the box, and the steel washer on the side of the handle screw.
6. Place the U-bracket in the desired position **A** or **B** and tighten softly the handle screws.

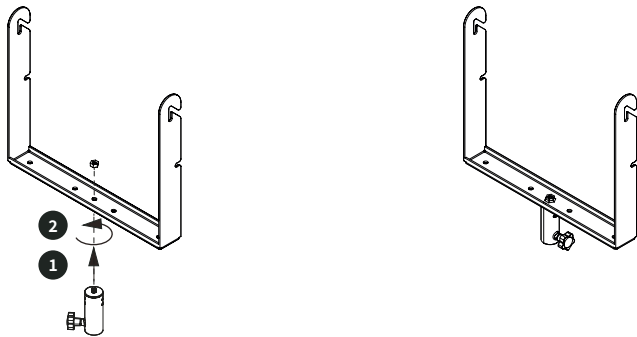



**Figure 8.** Attaching the **SMX 12UB** U-bracket to the **SMX 12A** monitor.  
Notice the three available mounting positions depending on the application.

To mount the monitor on a **SPS20** pole bar, use the **PS 35** adapter as follows:

7. Fix tightly the **PS 35** adapter to the **SMX 12UB** center-hole, using the M10 wing nut.
8. Loosen the star screw of the **PS 35** pole adapter, so the pole entrance is not obstructed.



**Figure 9.** **PS 35** pole adapter attached to the **SMX 12UB** U-bracket.

9. Push the U-bracket until the handle screw is in position **B** of the U-bracket's arm, as shown in figure 8. Tighten softly the handle screws.
10. Fix tightly the **SPS20** pole bar into the M20 thread of the subwoofer.
11. Lift the **SMX 12A** with the left and right handles of the box and insert the U-bracket into the pole bar. See figure 10.
12. Adjust the vertical angle of the box and fix the handle screws tightly.
13. Plug in the signal and power cables, and set the level and preset according to your application.

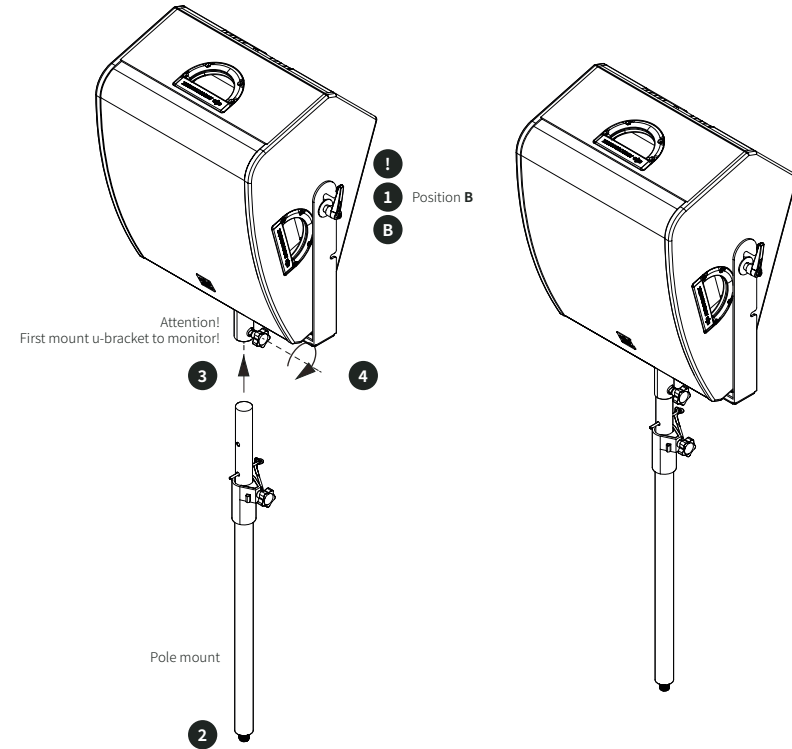

**Figure 10.** Mounting the **SMX 12A** with the U-bracket in the **SPS20** pole bar.

14. Secure mains and signal cables properly to prevent accidents due to cable entanglement.

## WALL MOUNTING

1. Fix the U-bracket on the wall. **Attention: Make sure to use appropriate mounting material.**
2. Make sure the arms of the **SMX 12UB** U-bracket are not bent and the opening between them is at least 47 cm. Otherwise, bend the arms slightly outwards, so you can get the box between them without trouble.
3. Unscrew the black countersink screws from M10 fly points on the left and right side of SMX 12A.
4. Onto the thread of each M10 handle screw, put first a steel washer and secondly, a silicone washer.
5. Fix the handle screws into the fly points. Turn 3 or 4 times to keep them in place.
6. Push the silicone washer close to the cabinet's side panel, and the metal washer close to the handle screw, so the U-bracket arm can easily get between both washers.
7. Use the two left and right cabinet handles to lift and hang the box onto the U-Bracket arms.
8. Make sure the handle screws are fixed in position **A** of U-bracket slot.
9. Adjust the vertical angle of the box and fix the handle screws tightly.
10. Plug in the signal and power cables, and set level and preset according to your application.
11. If you want to be very close to the wall and have SMX 12A pointing downwards, you can use the notch position **C** on the U-bracket. See figure 11.

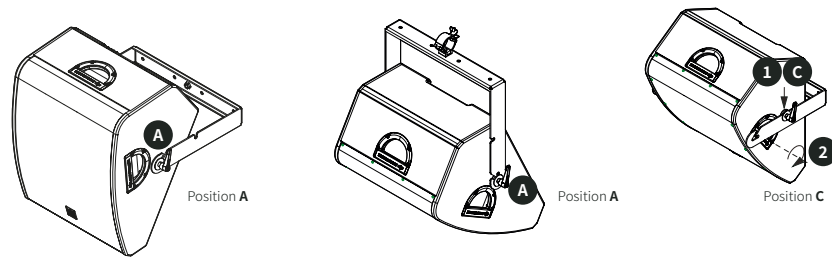

Figure 11. Different aiming angles for wall- and truss-mount installation.

## APPLICATIONS

### MONITOR

SMX 12A is fully capable to work as high quality monitor for any signal source, may it be voice, keyboard, drums or other instruments. Advanced limiter algorithms reduce otherwise typical limiter pumping to a bare minimum and keep undistorted, dynamic sound reproduction up to high levels.

For monitor applications, choose one of the **FULL** presets from 1 to 4, which suits your preferred sound best. The SMX 12A will react precisely to any additional equalization you may want to apply to further match your preferred performance.



A better practice when equalizing is to reduce levels in the undesired frequency ranges, boosting the desired ones. This guarantees also a maximum dynamic range.

### PA SYSTEM WITH SUBWOOFER

SMX 12A can be used together with matching active subwoofers to work as a small, transportable yet powerful PA system. Use the pole bar adapter **PS 35** to attach the U-bracket to the pole bar **SPS20**. The **SPS20** can be screwed into the M20 threads in the top panels of our subwoofers.

SE AUDIOTECHNIK's® subwoofers matching the SMX 12A would be:

- M-F3A S15 PRO
- B15A

Choose any of the **TOP** presets at the SMX 12A to activate a matching high-pass filter at 120 Hz. For the active subwoofers detailed, chose the related "SMX 12A" preset.

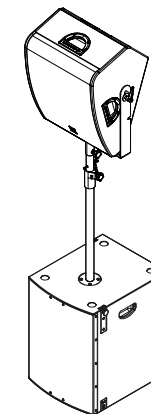

The very high efficiency of the compression driver amplifies the electronics' inherent noise floor. Additional equipment like mixer and other added devices, can increase this noise floor to a very audible hiss.



In those cases, you can reduce the gain to -4 or -10dB. The noise floor will be reduced by the same magnitude.

Figure 12. SMX 12A pole-mounted over an S15 subwoofer from SE AUDIOTECHNIK®.

# SPECIFICATIONS

## TECHNICAL SPECIFICATIONS

PARAMETER	VALUE
<b>ELECTRO-ACOUSTICAL</b>	
Frequency response (-3 dB) <sup>1</sup>	65 Hz - 17 kHz
Frequency range (-10 dB) <sup>1</sup>	60 Hz - 20 kHz
Coverage angles (-6 dB) [H x V]	60° x 60°
Maximum Peak SPL <sup>1</sup>	129 dB
System type	2-way coaxial system
Crossover frequency	1.4 kHz
Transducers	Coaxial driver with: LF: 1 x 12" driver (3" voice coil), HF: 1" compression driver (1.7" voice coil)
Enclosure type	Vented box
<b>AMPLIFICATION</b>	
Type	2 channel, class-D with SMPS
Total power <sup>2</sup>	484 W
Output power per channel	LF: 416 W @ 6.5 Ω, HF: 68 W @ 14 Ω
Protection	Short circuit, overheating, overcurrent and overvoltage, multiband limiter
Connectors	Input signal: balanced XLR 3-pin female, or balanced 6.5 mm TRS jack. Link output: balanced XLR 3-pin male Power input: powerCON® 20A Power link output: powerCON® 20A
Operating Voltage	100 VAC - 240 VAC, 50 - 60 Hz
Wiring	Pin N: Neutral, Pin L: Conductor, Pin E: Ground
Input sensitivity	0 dBu
DSP	48 kHz/24 bit with extended dynamics, Processing latency: 1.1 ms
Processing	Level, factory EQ presets
User controls	Power: ON/OFF switch Level: 8-position rotary knob (-50, -20, -10, -4, -2, 0, +2, +4) DSP presets: 8-position rotary knob
<b>MECHANICAL</b>	
Product dimensions [H x W x D] (Including rigging)	368 x 450 x 575 mm
Net weight	22 kg
Packaging dimensions [H x W x D]	447 x 535 x 660 mm
Total weight	25 kg
Cabinet	15 mm plywood
Cabinet finishing	Black polyurea coating
Grille	Powder coated perforated steel
Hardware	1 top and 2 side handles embedded in cabinet, Rubber feet, 2 x M10 for U-bracket mounting
<b>ACCESSORIES</b>	
U-bracket	SMX 12UB
Pole bar	SMX 12TC
Transport cover	SPS20
M10 screw to 35mm pole socket adaptor	PS35

<sup>1</sup> Measured with 12 dB Crest factor Pink Noise, half space

<sup>2</sup> Total power value is the sum of all individual channel output power

## MECHANICAL DRAWINGS

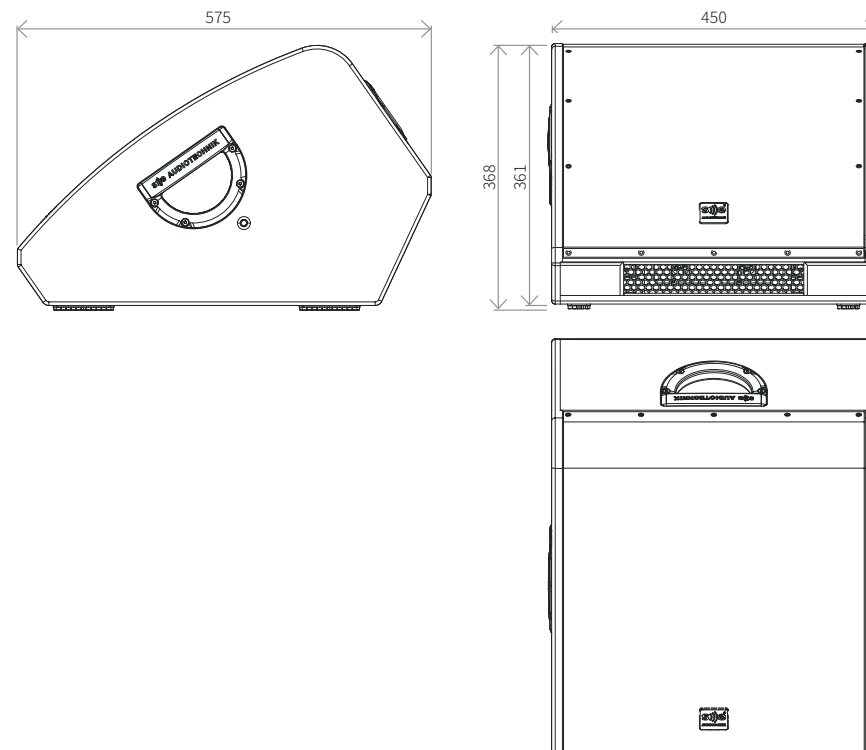

Figure 13. SMX12A views and dimensions. Annotations given in millimeters.

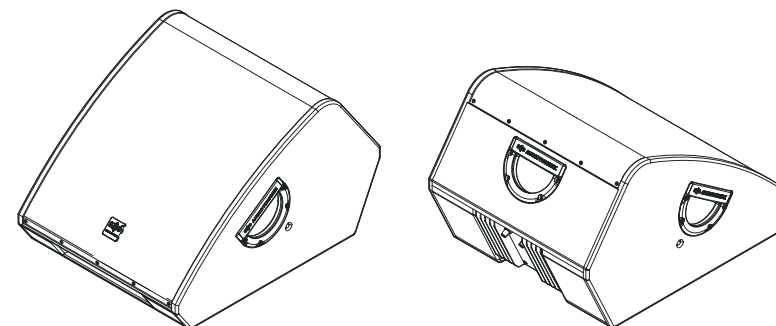

Figure 14. SMX 12A isometric views.

# MANUFACTURER'S DECLARATIONS

## LIMITED WARRANTY

This limited warranty applies to SE AUDIOTECHNIK® branded products.

The statutory warranty rights towards the seller are not affected by this guarantee. In fact, it justifies additional independent warranty claims towards SE Audiotechnik.

SE AUDIOTECHNIK® warrants that the SE AUDIOTECHNIK® product purchased from SE AUDIOTECHNIK® or from an SE AUDIOTECHNIK® authorized reseller, is free from defects in materials or workmanship under normal use, for a period of three years from the date of purchase.

The limited warranty period starts on the date of purchase. To receive warranty services, proof of the purchase must be provided. The dated sales or delivery receipt, stating the date of purchase, is the proof of purchase.

Should products of the brands named above be in need of repair within the limited warranty period, you are entitled to warranty services according to the terms and conditions stated in this document.

This limited warranty extends only to the original purchaser of this SE AUDIOTECHNIK® branded product and is not transferable to anyone who obtains ownership of the SE AUDIOTECHNIK® product from the original purchaser. During the limited warranty period, SE AUDIOTECHNIK® will repair or replace the defective component parts or the product. All component parts or hardware products removed under this limited warranty become the property of SE AUDIOTECHNIK®.

In the unlikely event that the SE AUDIOTECHNIK® product has a recurring failure, SE AUDIOTECHNIK®, at its discretion, may elect to provide a replacement unit of SE AUDIOTECHNIK® choice that is at least equivalent to your SE AUDIOTECHNIK® branded product in hardware performance.

SE AUDIOTECHNIK® does not warrant that the operation of this product will be uninterrupted or error-free.

SE AUDIOTECHNIK® is not responsible for damage that occurs as a result of your failure to follow the instructions included with the SE AUDIOTECHNIK® branded product.

This limited warranty does not apply:

- to wear parts
- to any product from which the serial number has been removed or that has been damaged or rendered defective as the result of an accident
- in case of misuse, abuse, or other external causes
- by operation outside the usage parameters stated in the user's documentation
- by use of spare parts not manufactured or sold by SE AUDIOTECHNIK®
- by modification or service by anyone other than SE AUDIOTECHNIK®

These terms and conditions constitute the complete and exclusive warranty agreement between the purchaser and SE AUDIOTECHNIK® regarding the SE Audiotechnik branded product purchased.

## LIMITATION OF LIABILITY

If the SE AUDIOTECHNIK® branded hardware product fails to work as warranted above, the sole and exclusive remedy shall be repair or replacement. SE AUDIOTECHNIK®'s maximum liability under this limited warranty is explicitly limited to the lesser of the price it has been paid for the product, or the cost of repair or replacement of any hardware components that malfunction in conditions of normal use.

SE AUDIOTECHNIK® is not liable for any damages caused by the product or the failure of the product, including any lost profits or savings or special, incidental or consequential damages. SE AUDIOTECHNIK® is not liable for any claim made by a third party or made by the purchaser for a third party.

This limitation of liability applies whether damages are sought, or claims are made, under this limited warranty or as a tort claim (including negligence and strict product liability), a contract claim, or any other claim. This limitation of liability cannot be waived or amended by any person. This limitation of liability will be effective even if the purchaser

has advised SE AUDIOTECHNIK®, or an authorized representative of SE AUDIOTECHNIK®, of the possibility of any such damages.

This limitation of liability however, will not apply to claims for personal injury.

This limited warranty gives the purchaser specific legal rights. There may also be other rights that may vary from state to state or from country to country. The purchaser is advised to consult applicable state or country laws for a full determination of his rights.

## REQUESTING WARRANTY SERVICE

To request warranty service for the product, the purchaser must contact SE AUDIOTECHNIK® or the SE AUDIOTECHNIK® authorized reseller from which the product was purchased.

## EC DECLARATION OF CONFORMITY

This device meets the essential requirements and further relevant specifications of the Directives of the European Union. The detailed declaration, and the list of these Directives and the Harmonized Standards, is available in our website [www.se-audiotechnik.de](http://www.se-audiotechnik.de).

## CORRECT DISPOSAL OF THIS PRODUCT (ELECTRICAL WASTE)

(Applicable in the European Union and other European countries with separate collection systems)

This marking, shown on the product or its literature, indicates that it should not be disposed with other household wastes at the end of its working life. To prevent possible harm to the environment or human health from uncontrolled waste disposal, please separate this from other types of waste and recycle it responsibly to promote the sustainable reuse of material resources.

Household users should contact either the retailer where they purchased this product, or their local government office, for details on where and how they can recycle this item in an environmentally friendly manner.

Business users should contact their supplier and check the terms and conditions of the purchase contract. This product should not be mixed with other wastes for disposal.

## WEEE-DECLARATION

This SE AUDIOTECHNIK® product was developed and manufactured with high quality materials and components which can be recycled and/or reused. This symbol indicates that electrical and electronic equipment must be disposed separately from normal waste at the end of its operational lifetime.

Please dispose this product by bringing it to your local collection point or recycling centre for such equipment. This will help to protect the environment in which we all live.

# ANNEX A – PRESETS PROFILE CURVES

These graphs detail the profile curves of the DSP for the two group of presets, **FULL** and **TOP**.

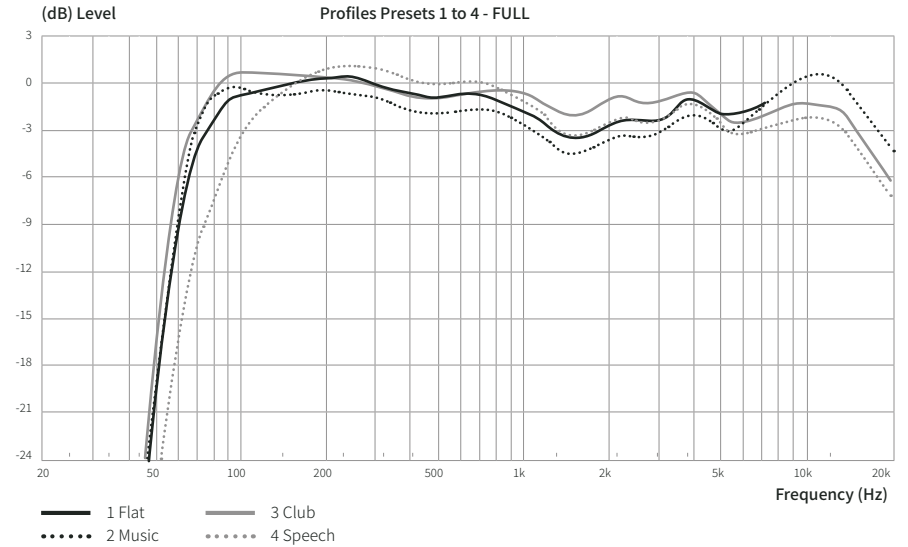

Figure 15. Profile curves of the FULL presets.

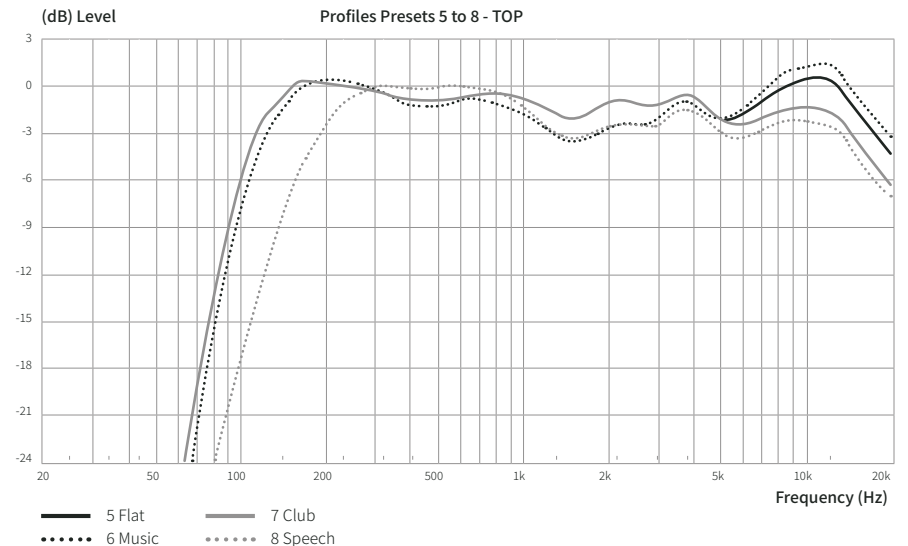

Figure 16. Profile curves of the TOP presets.

**S))E' AUDIOTECHNIK**

**HEAD OFFICE**

Neuenhofer Strasse 42-44  
42657 Solingen, Germany

info@se-audiotechnik.de

**ASIA-PACIFIC DEVELOPMENT CENTER**

No. 8 Development Zone Road  
Huimin Sub-district, Jiashan County, Zhejiang, 314112, P.R. China

service@se-audiotechnik.com

**www.se-audiotechnik.de**



Designed in Germany

**Version 2022/01**

S))E' AUDIOTECHNIK, all rights reserved. The technical data and the functional product characteristics can be subject to modifications. The photocopying, translation, and all other forms of copying of fragments or of the integrity of this user manual is prohibited.

© 2022 S))E' AUDIOTECHNIK is a registered trademark of Speaker Electronic (Jia Shan) Co. Ltd.

EASE® is a registered trademark of AFMG Technologies GmbH.  
Neutrik® and powerCON® are registered trademarks of Neutrik AG.